

**Dome Heat Shrinkable Seal Fiber Optic Splice Closure  
(FOSC)**



**GJS- D096M1  
Installation Manual**

## 1. Scope of application

This Installation Manual suits for the Fiber Optic Splice Closure (Hereafter abbreviated as FOSC), as the guidance of proper installation.

The scope of application is: aerial, underground, wall-mounting, duct-mounting and handhole- mounting. The ambient temperature ranges from  $-40^{\circ}\text{C}$  to  $+65^{\circ}\text{C}$ .

## 2. Basic structure and configuration

### 2.1 Dimension and capacity

Outside dimension (Height x Diameter)	472mm×193mm
Weight (excluding outside box)	3000 g— 3600g
Number of inlet/out ports	4+1 pieces in general
Diameter of fiber cable	$\Phi 8\text{mm}\sim\Phi 20\text{mm}$
Capacity of FOSC	Bunchy:24-96 (cores), Ribbon: up to384 (cores)

### 2.2 Main components

No.	Name of components	Quantity	Usage	Remarks
1	FOSC cover	1 piece	Protecting fiber cable splices in whole	Height x Diameter 385mm x 147mm
2	Fiber optic splice tray (FOST)	Max. 4 trays (bunchy ribbon)	Fixing heat shrinkable protective sleeve and holding fibers	Suitable for: Bunchy:24(cores) Ribbon:12 (pieces)
3	Fiber holding tray	1 pcs	Holding fibers with protective coat	
4	Base	1set	Fixing internal and external structure	
5	Plastic hoop	1 set	Fixing between FOSC cover and base	
6	Seal fitting	1 piece	Sealing between FOSC cover and base	
7	Pressure testing valve	1 set	After inject air, it is used for pressure testing and sealing testing	Configuration as per requirement
8	Earthing deriving device	1 set	Deriving metal parts of fiber cables in FOSC for earthing connection	Configuration as per requirement

### 2.3 Main accessories and special tools

No.	Name of accessories	Quantity	Usage	Remarks
1	Heat shrinkable protective sleeve		Protecting fiber splices	Configuration as per capacity
2	Nylon tie		Fixing fiber with protective coat	Configuration as per capacity

3	Heat shrinkable fixing sleeve (single)		Fixing and sealing single fiber cable	Configuration as per requirement
4	Heat shrinkable fixing sleeve (mass)		Fixing and sealing mass of fiber cable	Configuration as per requirement
5	Branching clip		Branching fiber cables	Configuration as per requirement
6	Earthing wire	1 piece	Putting through between earthing devices	
7	Desiccant	1 bag	Put into FOSC before sealing for desiccating air	
8	Labeling paper	1 piece	Labeling fibers	
9	Aluminum-foil paper	1 piece	Protect the bottom of FOSC	

### 3. Necessary tools for installation

#### 3.1 Supplementary materials (to be provided by operator)

Name of materials	Usage
Scotch tape	Labeling, temporarily fixing
Ethyl alcohol	Cleaning
Gauze	Cleaning

#### 3.2 Special tools (to be provided by operator)

Name of tools	Usage
Fiber cutter	Cutting off fiber cable
Fiber stripper	Strip off protective coat of fiber cable
Combo tools	Assembling FOSC

#### 3.3 Universal tools(to be provided by operator)

Name of tools	Usage and specification
Band tape	Measuring fiber cable
Pipe cutter	Cutting fiber cable
Electrical cutter	Take off protective coat of fiber cable
Combination pliers	Cutting off reinforced core
Screwdriver	Crossing/Paralleling screwdriver
Scissor	
Waterproof cover	Waterproof, dustproof
Metal wrench	Tightening nut of reinforced core

#### 3.4 Splicing and testing instruments (to be provided by operator)

Name of instruments	Usage and specification
Fusion Splicing Machine	Fiber splicing
OT DR	Splicing testing
Provisional splicing tools	Provisional testing
Fire sprayer	Sealing heat shrinkable fixing sleeve

Notice: The above-mentioned tools and testing instruments should be provided by the operators themselves.

#### 4. Installation flow chart

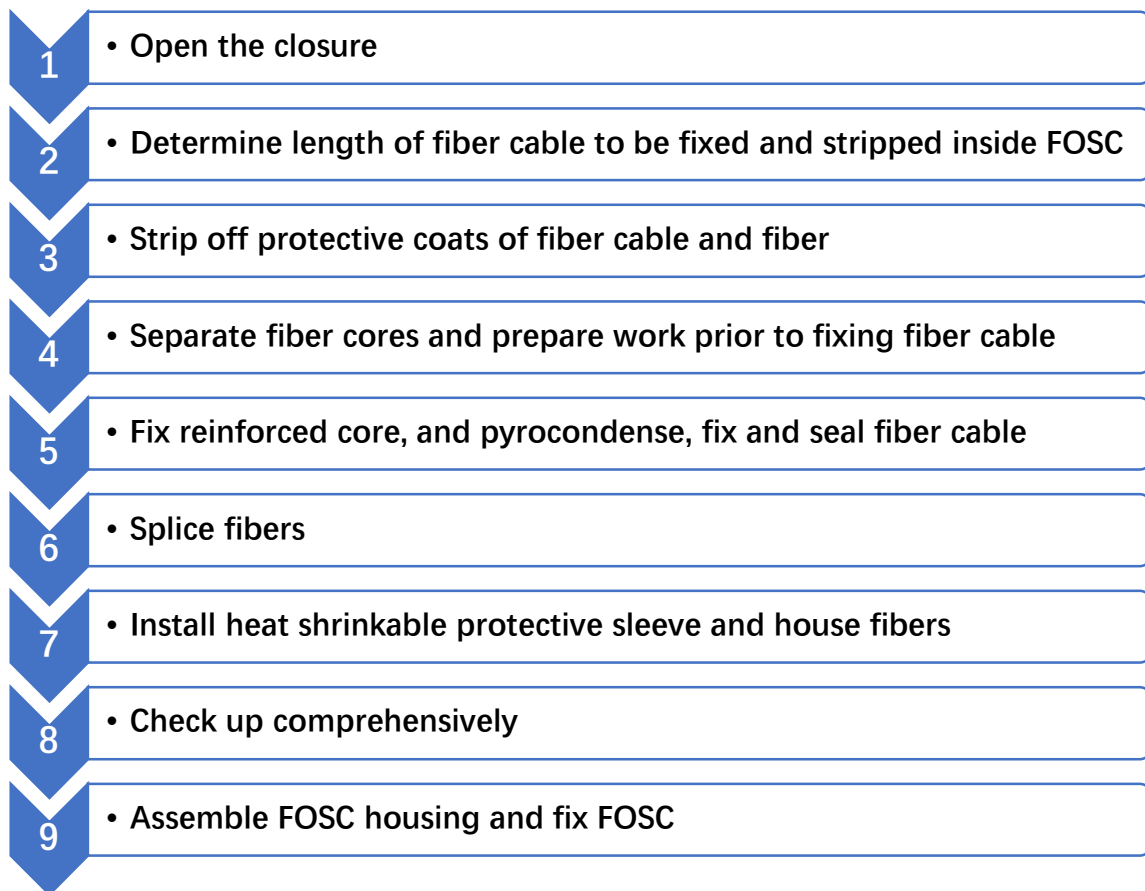

#### 5. The process of installing FOSC.

##### 5.1 Step One - Open the closure

- 5.1.1 Cleaning the locale and determine where to install the FOSC and then place fiber cables required.
- 5.1.2 Check whether the main components and accessories have been well prepared inside the package.
- 5.1.3 Open the closure
  - ① Demount hoop fixing bolt and pull hoop locking system out, then proceed in demounting the hoop.
  - ② Pull the FOSC cover upwards out, installation could begin.
- 5.1.4 See Drawing 1

**Important issues:** If the weather condition is not good enough, then a tent must be pitched for waterproof and dustproof.



**Drawing 1**

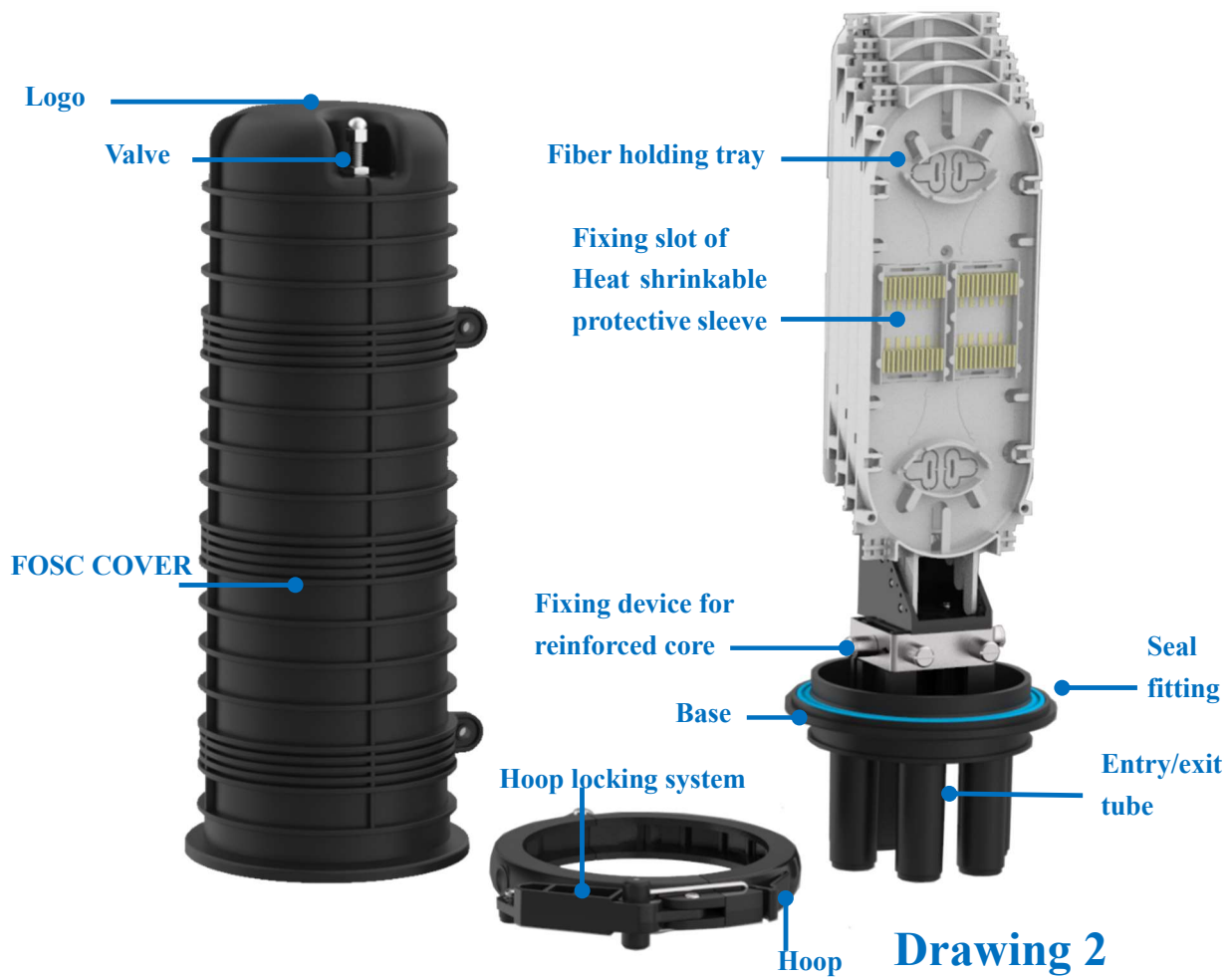

**Drawing 2**

**5.2 Step Two -Determine length of fiber cable to be fixed and stripped inside FOSC**

- 5.2.1 If all fibers are for branch splicing, please refer to Drawing 3(A) for stripping length.
- 5.2.2 If some fibers are for straight-through, while others are for branch splicing, please refer to Drawing 3(B) for stripping length.
- 5.2.3 See Drawing 2.

**Important issues:** 1. Reserve enough length of fiber cable to be spliced.  
 2. Stripping length also could be decided by customers according to installation requirement

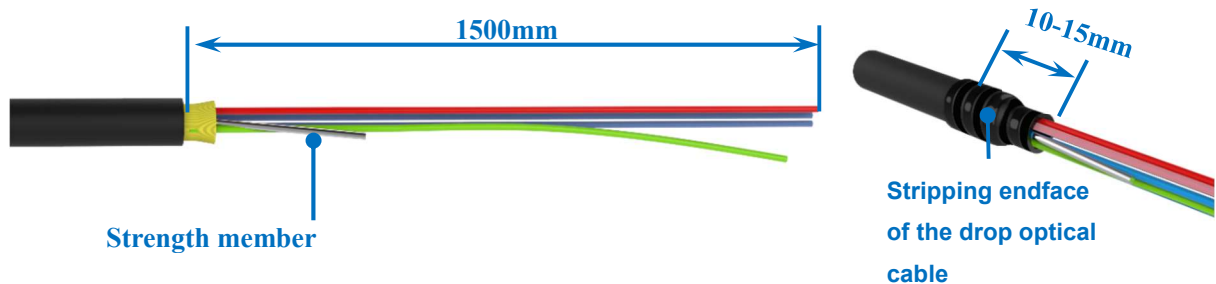

**Drawing (3)A**

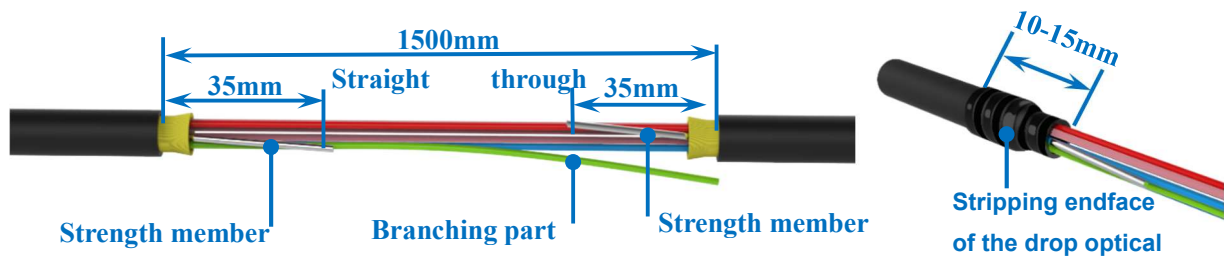

**Drawing (3)B**

### 5.3 Step Three –Strip off protective coat of fiber cable and fiber

5.3.1 Strip off protective coat of fiber cable from the temp. locating mark with the cutter and the stripper, please refer to Drawing 3 for stripping length. Stripping length also could be decided according to installation requirement

5.3.2 See Drawing 3.

**Important issues:** If it is difficult to pull all the protective coat of fiber cable at one time, strip it off section by section to avoid fiber breakage.

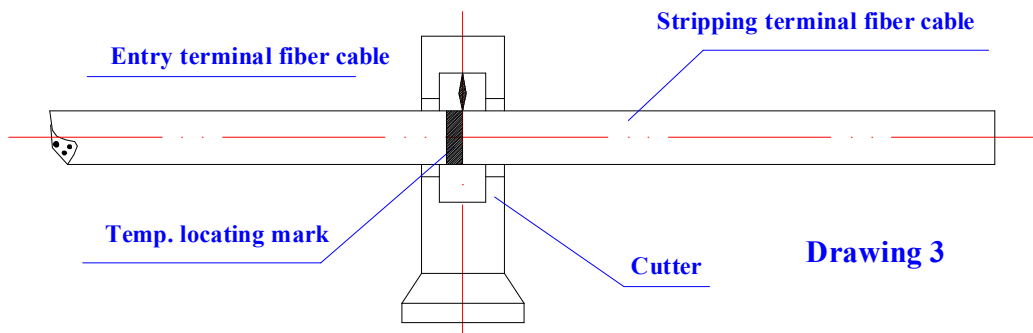

### 5.4 Step Four – Separate fiber cores and prepare work prior to fixing fiber cable.

5.4.1 Wind 2 layers of insulation tape on protective coat of fiber core for protection.

Meanwhile, get rid of the stuffing to separate fiber core and clean them. Form a ring with the diameter of 100mm or so and fix it on the fiber temporarily by adhesive tape.

5.4.2 Depending on fiber cable stripped, the following two cases are available.

- ① All fibers are to be branched after being spliced completely.
- ② Some of fibers are for straight-through after being winded, while the others are for branch splicing.

5.4.3 The FOSC is provided with 5 single entry/exit tubes which suit for single fiber cables with max. diameter  $\phi 20$  mm and 1 mass entry/exit tube which suits for 1 piece of fiber cable with max. diameter  $\phi 32$ mm or 2 pieces of fiber cables with max. diameter  $\phi 25$ mm or multi-pieces of fiber cables with short diameter.

5.4.4 Mass entry/exit tube is required if some fibers are for straight-through

5.4.5 The corresponding entry/exit tube cover could be slightly knocked out with screwdriver from inside to outside according to number and diameter of fiber cable

required.

5.4.6 Reserve reinforced core in 35mm length and cut off the unnecessary ones.

5.4.7 See Drawing 3.

**Important Issues:** Entry/exit tubes are to be selected accurately to make it easy for splicing and sealing.

### 5.5 Fix reinforced core, and pyrocondense, fix and seal fiber cable.

5.5.1 Insert fiber cable into the corresponding heat shrinkable fixing tube, further insert the them into entry/exit tube at the bottom of FOOSC.

5.5.2 Use to loosen the screws of reinforced core with a screwdriver, which is to be inserted into the fixing slot afterward and tighten it. Then retighten it with a screwdriver .

5.5.3 Hitch heat shrinkable fixing sleeve to the fiber cable till its root by hand.

5.5.4 Please refer to Drawing 5 for installing branching clip.

5.5.5 Heat heat shrinkable fixing sleeve with fire sprayer to make it hugging entry/exit tube and fiber cable to reach complete sealing.

5.5.6 See Drawing 5

**important issue:** 1. Screws of reinforced core should be tightened.

2. While heating, heat shrinkable fixing tube should shrink evenly, and there should be no bubbles, pores and other defects inside the tube.

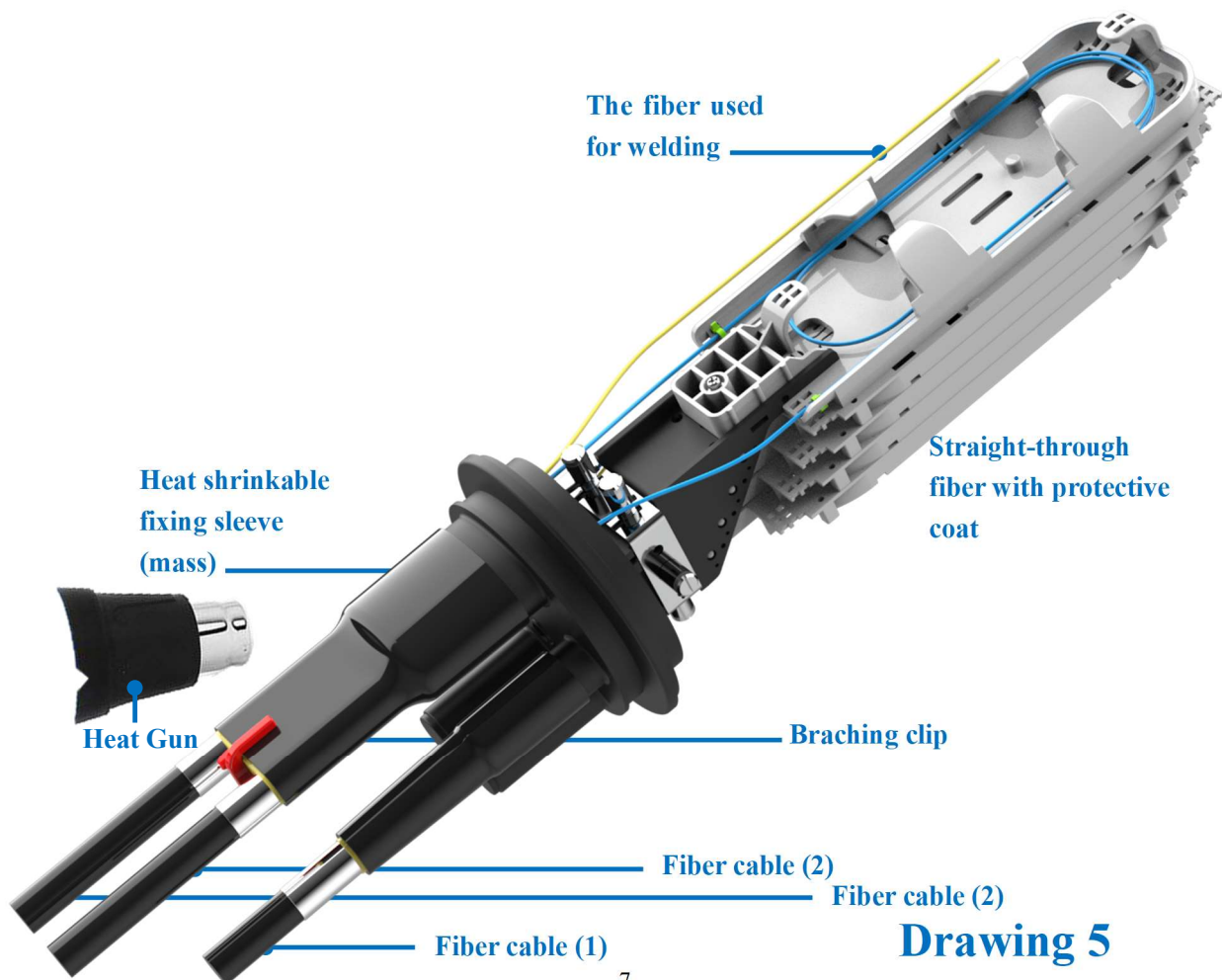



## 5.6 Step Six - Splice fibers

5.6.1 Follow user manual of fusion splicing machine to splice fiber.

**Important issue:** pay attention to the twist and bend of fiber

## 5.7 Step Seven -Install heat shrinkable protective sleeve and house fibers.

5.7.1 When having completed splicing the fibers, the first fiber ring should be housed on the farthest side of FOST, the remaining fiber optic should be winded, forming a ring with diameter not less than 80mm. then put it into FOST (Fiber Optic Splice Tray) together with heat shrinkable protective sleeve.

( Firstly fix heat shrinkable protective sleeve into the slot, then enlarge the diameter of fiber ring properly.)

5.7.2 see Drawing 6

**Important issue:** pay attention to the twist and bend of fiber.

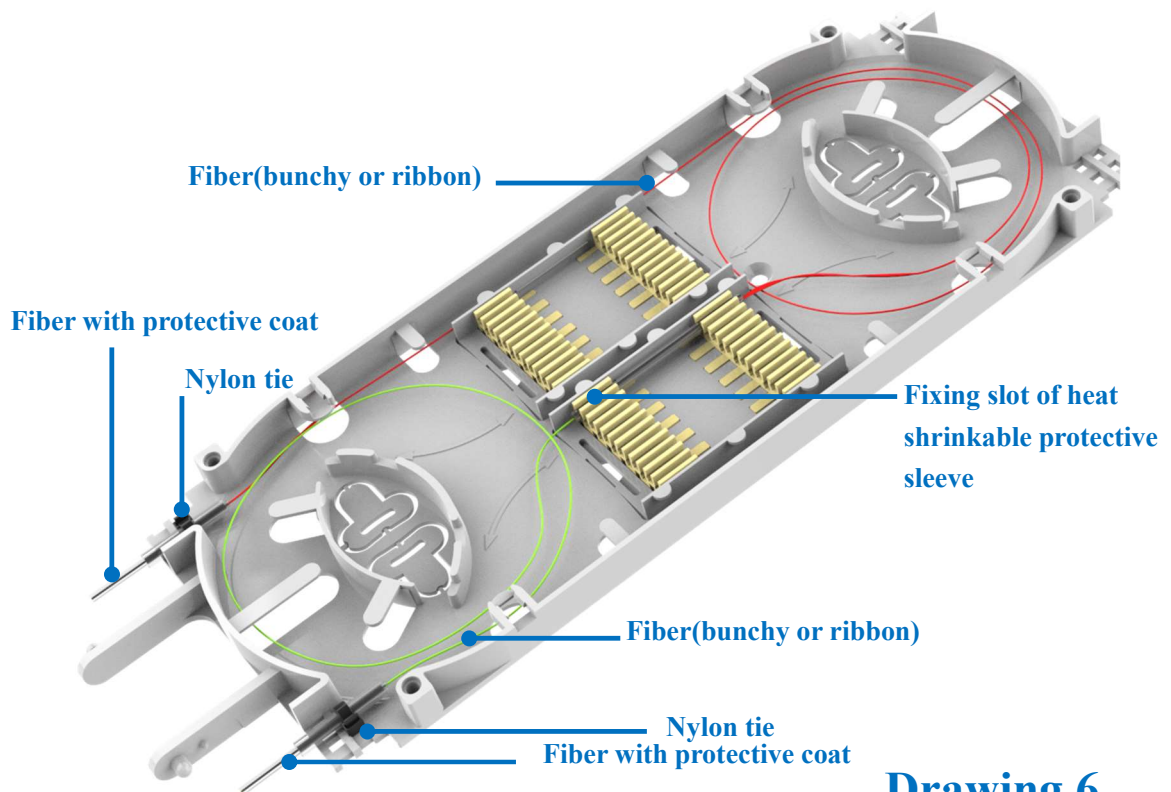

**Drawing 6**

## 5.8 Step Eight - Check up comprehensively

To ensure the technical requirements, the following instructions must be followed:

- 5.8.1 Fibers with protective coat are fixed with nylon tie at the entrance of FOST.
- 5.8.2 Grommet should be pressed from inside to outside in order to properly install FOST.
- 5.8.3 Straight-through and reserved fibers with protective coat should be winded to the fiber holding tray.
- 5.8.4 Check whether the internal tighteners and fixing nut of reinforced core are well

tightened.

5.8.5 Check whether seal fitting is installed neatly and smoothly.

5.8.6 Check whether heat shrinkable fixing sleeve is reliable and sealing completely.

5.8.7 See Drawing 4.

**Important issues:** If any problems occur, they should be solved right away.

### 5.9 Step Nine – Assemble FOSC housing and fix FOSC

5.9.1 Put desiccant into FOSC.

5.9.2 Put FOSC cover on base directly.

5.9.3 Install plastic hoop between FOSC cover and base, tighten hoop locking system, which is to be fixed by hoop fixing bolt then.

5.9.4 FOSC installation

① Strand Overhead application: Fasten the steel wire with a metal clip. Please refer to Drawing 7

② Pole application: fix metal hoop and transom to the pole. Please refer to Drawing 8

③ Wall mounting application: fix the bracket on the wall with bolt. (metal hoop is not required.) Drawing 9

④ Underground application: metal hoop is not required.

**Important issues:** 1. Pay attention while installing plastic hoop.

2. The specification of bolt for fixing the bracket is M8.



**Drawing 7**

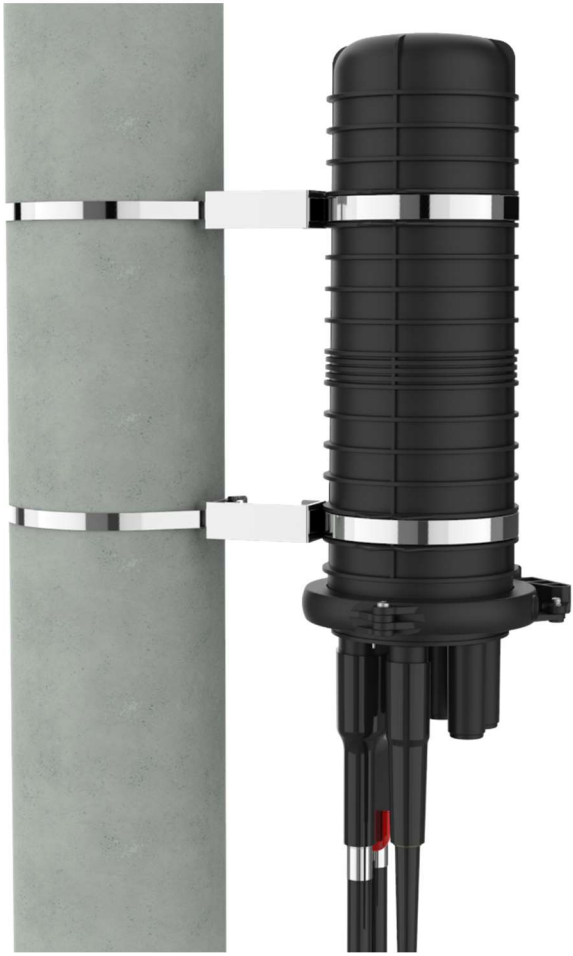

**Drawing 8**



**Drawing 9**